

Automotive Climate Products



 **demmon®**

PROFESSIONAL COOLING & HEATING SOLUTIONS – HIGH PERFORMANCE AND RELIABILITY

The image shows a modern building at night with a large glass facade. The Demmon logo is illuminated on the top edge of the building. The sky is dark with some clouds. A Turkish flag is visible on a pole in the foreground to the left.

demmon

Introduction

Combining comfort, technology, and durability, Demmon enhances every journey with its advanced in-vehicle climate control solutions. Our wide product range, including vehicle refrigerators, parking air conditioners, diesel heaters, and supporting equipment, is developed to provide drivers with uninterrupted comfort in all seasons.

Designed to meet the evolving demands of modern life and long-distance travel, our products offer low energy consumption, high performance, and long-lasting reliability. Even under challenging road conditions, Demmon climate control systems deliver dependable performance, providing powerful solutions for both individual users and the professional transportation industry.

At Demmon, our goal is to combine technology with functionality, elevate in-vehicle living standards, and deliver a comfortable driving experience under all conditions.

 demmon®



PARKING AIR CONDITIONER

PARKING AIR CONDITIONER
HAIER 6TH SERIES



HERMETIC
COMPRESSOR



BRUSHLESS
ENGINE



TURBO
MODE



TROUBLE
DETECTION



SLEEP
MODE



BATTERY
PROTECTION



ADJUSTABLE
AIR VENT



FEATURE

PAC20HSXG5-W1

POWER SUPPLY	DC 24V (22.5V- 30V)
COOLING CAPACITY	2000 W
RATED POWER / CURRENT	800 W / 33.4 A
MAX POWER / CURRENT	1032 W / 43 A
AIRFLOW (INDOOR)	380~1300 M ³ /H
NOISE LEVEL	63 DB(A)
MASS (WEIGHT)	30 KG
SWING FUNCTION	MANUAL (MANUEL)
INDOOR UNIT	343X360X133 MM
OUTDOOR UNIT	880X840X180 MM

PARKING AIR CONDITIONER
HISENSE 6TH GENERATION



HERMETIC
COMPRESSOR



BRUSHLESS
ENGINE



TURBO
MODE



TROUBLE
DETECTION



SLEEP
MODE



BATTERY
PROTECTION

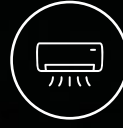

ADJUSTABLE
AIR VENT



VOLTAGE	DC-24V
MAX OUTPUT POWER	960W
MAX INPUT CURRENT	40A
INPUT POWER / CURRENT	800 W / 33.3A
ENERGY EFFICIENCY	2.75W/W
COOLING FREQUENCY RANGE	20-62HZ
FAN SPEED (HIGH/MEDIUM/LOW)	1400/1700/1920
INDOOR UNIT DIMENSIONS (L×W×H)	830×860×175
COOLING TEMPERATURE RANGE	16-32°C
COOLING CAPACITY	2260W
OUTDOOR UNIT DIMENSIONS (L×W×H)	490×270×130
AIRFLOW CAPACITY	380 M ² /H
NET/GROSS WEIGHT	30 / 38.5 KG

PARKING AIR CONDITIONER
DEMMON SLIMCOOL PRO - 12L



HERMETIC
COMPRESSOR



BRUSHLESS
ENGINE



TURBO
MODE



TROUBLE
DETECTION



SLEEP
MODE



BATTERY
PROTECTION



ADJUSTABLE
AIR VENT

ADVANCED PERFORMANCE, SUPERIOR COOLING

- Fast cooling performance with turbo function
- Faster service support with fault detection system
- Uniform cabin cooling with vertical airflow feature
- Quiet and automatic cooling with sleep mode
- Low energy consumption and high performance with brushless motor



FEATURE	SLIMCOOL PRO-12L (24V)	SLIMCOOL PRO-12L (12V)
COOLING CAPACITY	2400W	2100W
VOLTAGE	DC 24V	DC 12V
RATED POWER	780W	700W
EVAPORATOR AIR FLOW	450 M3/H	450 M3/H
CONDENSER AIR FLOW	1800 M3/H	1800 M3/H
REFRIGERANT GAS / AMOUNT	R134A / 750G	R134A / 750G
OIL TYPE	RH68	RH68
OUTDOOR UNIT DIMENSIONS	925 X 788 X 187 MM	925 X 788 X 187 MM
MIN. MOUNTING HOLE	600 X 300 MM	600 X 300 MM

PARKING AIR CONDITIONER
HAIER 5TH SERIES



HERMETIC
COMPRESSOR



BRUSHLESS
ENGINE



TURBO
MODE



TROUBLE
DETECTION



SLEEP
MODE



BATTERY
PROTECTION



VOLTAGE	DC-24V
INPUT VOLTAGE RANGE	22.5V – 30V
MAX INPUT POWER	1032W
INPUT POWER / CURRENT	800 W / 33 A
COOLING CAPACITY	2000W
INDOOR UNIT AIR VOLUME	380 M ³ /H
INDOOR UNIT DIMENSIONS (L×W×H)	980×840×180
COOLING TEMPERATURE RANGE	16–32°C
OUTDOOR UNIT DIMENSIONS (L×W×H)	343×360×133
AIRFLOW CAPACITY	380 M ³ /H
NET/GROSS WEIGHT	33 / 38.5 KG

PARKING AIR CONDITIONER
DEMMON SLIMCOOL DUO 3H



TURBO
MODE



TROUBLE
DETECTION



SLEEP
MODE



BATTERY
PROTECTION



ADJUSTABLE
AIR VENT



TIMER
FUNCTION



LOW VOLTAGE PROTECTION RANGE

19V–24V (DEFAULT: 21V)

HIGH VOLTAGE PROTECTION

32V

TEMPERATURE SETTING RANGE

16°C – 32°C

FAN SPEED LEVELS

1 – 6 LEVELS

REFRIGERANT

R134A

NORMAL LOW PRESSURE VALUE

0.3MPA ± 0.05MPA

NORMAL HIGH PRESSURE VALUE

1.2MPA ± 0.1MPA
(AT 35°C AMBIENT TEMPERATURE)

LUBRICATION

60ML REFRIGERATION OIL

INSTALLATION DIMENSION

(MINIMUM WIDTH FOR VEHICLES WITH SUNROOF)

300MM

INSTALLATION DIMENSION

(MINIMUM LENGTH FOR VEHICLES WITH SUNROOF)

580MM

PARKING AIR CONDITIONER
DEMMON SLIMCOOL DUO 3



TURBO
MODE



TROUBLE
DETECTION



BATTERY
PROTECTION



ADJUSTABLE
AIR VENT



TIMER
FUNCTION



VOLTAGE PROTECTION RANGE

19V – 24V (FACTORY DEFAULT: 21V)

HIGH VOLTAGE PROTECTION

32V

TEMPERATURE SETTING RANGE

16°C – 32°C

REFRIGERANT TYPE

R134A

NORMAL OPERATING PRESSURE (35°C)

LOW PRESSURE: 0.3MPA ± 0.05MPA
HIGH PRESSURE: 1.2MPA ± 0.1MPA

FAN SPEED LEVELS

1 – 6 LEVELS

INSTALLATION DIMENSIONS

MINIMUM SUNROOF WIDTH: 300MM
MINIMUM SUNROOF LENGTH: 580MM

PARKING AIR CONDITIONER
RAINO POLAR X1



TURBO
MODE



TROUBLE
DETECTION



SLEEP
MODE



BATTERY
PROTECTION



FEATURE

DC-24V

DC-12V

COOLING CAPACITY

2000W

1800W

INPUT POWER / CURRENT

850W 36A

780W 36A

ENERGY EFFICIENCY

2.5 W/W

2.4 W/W

COOLING SPEED RANGE

1300–3000 RPM

1300–2300 RPM

FAN SPEED (HIGH/MEDIUM/LOW)

1500–2700 RPM

1500–2700 RPM

INDOOR UNIT DIMENSIONS (L×W×H)

869×935×172 MM

869×935×172 MM

COOLING TEMPERATURE RANGE

16–30°C

16–30°C

AIRFLOW CAPACITY

360 M³/H

360 M³/H

NET/GROSS WEIGHT

33 / 43 KG

33 / 43 KG

PARKING AIR CONDITIONER
RAINO POLAR ECO MINI



TURBO
MODE



TROUBLE
DETECTION



BATTERY
PROTECTION



ADJUSTABLE
AIR VENT



VOICE
ANNOUNCEMENT



FEATURE	NORMAL MODE	TURBO MODE
COOLING CAPACITY	1600W	1800W
POWER CONSUMPTION	200-660W	800W
AIRFLOW	350 M ³ /H	350 M ³ /H
NOISE LEVEL	63 DB(A)	63 DB(A)
ENERGY EFFICIENCY RATIO (EER)	2.4	2.7
OPERATING TIME	≥8 HOURS	≥4 HOURS

PARKING AIR CONDITIONER
DEMMON PORTABLE



COOLING CAPACITY	1500W / 5100 BTU
RATED VOLTAGE	DC 42V
RATED POWER	550W
RATED CURRENT	13.1A
REFRIGERANT	R290 / 110G
OPERATING TEMPERATURE	16°C ~ 30°C (60°F ~ 86°F)
NOISE LEVEL	44 – 56 DB (SOUND PRESSURE LEVEL)
PRODUCT DIMENSIONS (L×W×H)	516 × 305 × 336 MM
NET WEIGHT	10.8 KG (23.8 LB)
GROSS WEIGHT	15.5 KG



AUTO REFRIGERATORS

AUTO REFRIGERATOR
DEMMON DMT SERIES
 DMT-30 | DMT-40 | DMT-50



Smart Battery Guard

Features a 3-stage (Low/Med/High) battery protection system to prevent vehicle battery depletion.



Universal Power

Fully compatible with DC 12/24V (Vehicle) and AC 100-240V (Home/Office) power sources.



User-Centric Design

Dual-way opening or completely removable lid.

- Digital LED control panel with "MAX" (Fast Cooling) and "ECO" (Energy Saving) modes.

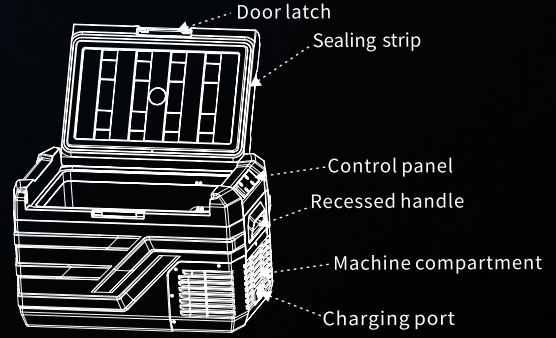

MODEL	DMT-30	DMT-40	DMT-50
RATED POWER		60W	
TEMPERATURE CONTROL RANGE		-20C - 20C	
NET WEIGHT	11.6 KG	12.7KG	13KG
CAPACITY (LITERS)	26.8 L	35.3 L	43.6 L
DIMENSIONS (LxWxH)	618X376X372	618X376X442	618X376X514

AUTO REFRIGERATOR
DEMMON DMU SERIES
 DMU-30 | DMU-40 | DMU-50



Dual-Zone Technology

Two separate compartments with independent storage areas for versatile cooling and freezing.



Smart Battery Guard

Features a 3-stage (Low/Med/High) battery protection system to prevent vehicle battery depletion.



Universal Power

Fully compatible with DC 12/24V (Vehicle) and AC 100-240V (Home/Office) power sources.



User-Centric Design

Dual-way opening or completely removable lid.

- Digital LED control panel with "MAX" (Fast Cooling) and "ECO" (Energy Saving) modes.

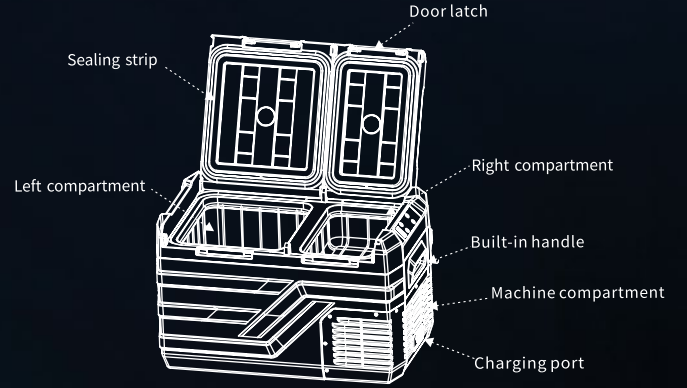

MODEL	DMU-30	DMU-40	DMU-50
RATED POWER		60W	
TEMPERATURE CONTROL RANGE		-20C - 20C	
NET WEIGHT	12 KG	13 KG	13.6 KG
TOTAL CAPACITY (LITERS)	23.3 L	31.3 L	39 L
LEFT ZONE CAPACITY	18.6 L	23.3 L	27.8 L
RIGHT ZONE CAPACITY	4.7 L	8 L	11.2 L
DIMENSIONS (LxWxH)	618X376X372	618X376X442	618X376X514

AUTO REFRIGERATOR
DEMMON DMF SERIES
DMF-20A | DMF-25A | DMF-30A



Smart Battery Guard

Features a 3-stage (Low/Med/High) battery protection system to prevent vehicle battery depletion.



Universal Power

Fully compatible with DC 12/24V (Vehicle) and AC 100-240V (Home/Office) power sources.



User-Centric Design

Dual-way opening or completely removable lid.

- Digital LED control panel with "MAX" (Fast Cooling) and "ECO" (Energy Saving) modes.

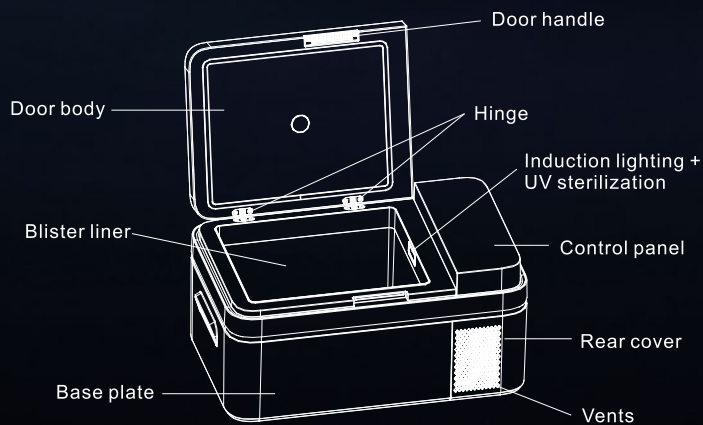



DMF-20A



DMF-25A



DMF-30A

MODEL	DMF-20A	DMF-25A	DMF-30A
INPUT VOLTAGE	DC 12V / 24V, AC100 - 240V		
TEMPERATURE CONTROL RANGE	-20C - 20C		
INSULATION MATERIAL	POLYURETHANE FOAM		
NET WEIGHT	10.4KG	11.2KG	11.6KG
PRODUCT SIZE(LxWxH)MM	623x378x280	623x378x325	623x378x370
PACKING SIZE(LxWxH)MM	653x431x330	653x431x375	653x431x420



SCAN FOR MORE

AUTO REFRIGERATOR
DEMMON WXR SERIES
 WXR-35 | WXR-45 | WXR-55



Dual-Zone Technology

Two separate compartments with independent storage areas for versatile cooling and freezing.



Smart Battery Guard

Features a 3-stage (Low/Med/High) battery protection system to prevent vehicle battery depletion.



Universal Power

Fully compatible with DC 12/24V (Vehicle) and AC 100-240V (Home/Office) power sources.



Damping Hinge Technology

Specially designed soft-close hinges that slow down the lid closure, reducing noise and preventing accidental slams.

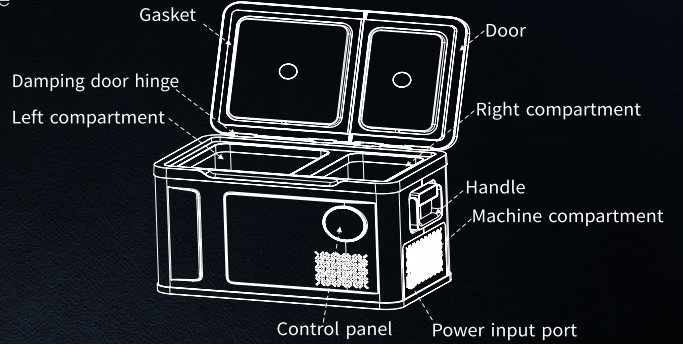

MODEL	WXR-35	WXR-45	WXR- 55
RATED POWER		60W	
TEMPERATURE CONTROL RANGE		-20C - 20C	
NOISE LEVEL		Less than 45 dB	
NET WEIGHT	15.9 KG	17 KG	18.1 KG
TOTAL CAPACITY (LITERS)	35 L	45 L	55 L
DIMENSIONS (LxWxH)	616X384X397	616X384X467	616X384X537
CLIMATE CLASS		T / ST / N	



AUTO REFRIGERATOR
DEMMON LXR SERIES
 LXR-35 | LXR-45 | LXR-55



Dual-Zone Technology

Two separate compartments with independent storage areas for versatile cooling and freezing.



Smart Battery Guard

Features a 3-stage (Low/Med/High) battery protection system to prevent vehicle battery depletion.



Universal Power

Fully compatible with DC 12/24V (Vehicle) and AC 100-240V (Home/Office) power sources.



User-Centric Design

Digital LED control panel with "MAX" (Fast Cooling) and "ECO" (Energy Saving) modes.

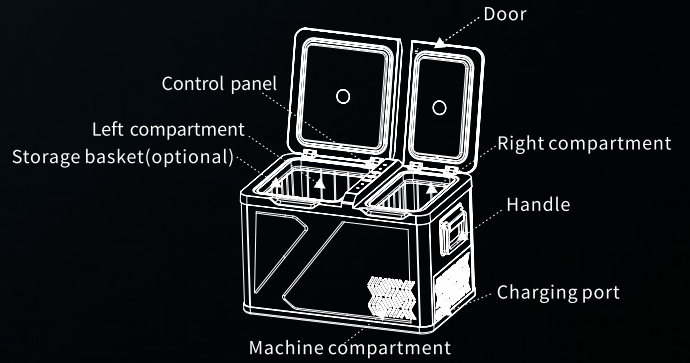

MODEL	LXR 35	LXR 45	LXR 55
RATED POWER		60W	
TEMPERATURE CONTROL RANGE		-20C - 20C	
NOISE LEVEL		Less than 45 dB	
NET WEIGHT	14.8 KG	15.6 KG	16.5 KG
TOTAL CAPACITY (LITERS)	35 L	45 L	55 L
DIMENSIONS (LxWxH)	689X412X415	689X412X485	689X412X555
CLIMATE CLASS		T / ST / N / SN	

AUTO REFRIGERATOR
DEMMON LN SERIES
 LN-9 | LN-15



Smart Battery Guard

Features a 3-stage (Low/Med/High) battery protection system to prevent vehicle battery depletion.



Universal Power

Fully compatible with DC 12/24V (Vehicle) and AC 100-240V (Home/Office) power sources.



User-Centric Design

Digital LED control panel with "MAX" (Fast Cooling) and "ECO" (Energy Saving) modes.

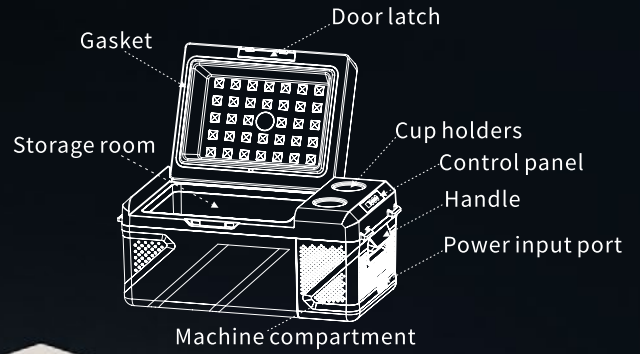

MODEL	LN 9	LN 15
RATED POWER	45W	60W
TEMPERATURE CONTROL RANGE	-20C - 20C	
NET WEIGHT	6.7 KG	15 KG
TOTAL CAPACITY (LITERS)	9 L	31.3 L
DIMENSIONS (LxWxH)	426X321X252	600X320X260
NOISE LEVEL	Less than 45 dB	



AUTO REFRIGERATOR
DEMMON JNP SERIES
JNP-15 FOR SUB-TRUNK



Tesla-Perfect Fit

Custom dimensions designed to slide directly into the **Tesla Model 3 and Model Y rear sub-trunk**.



Smart Battery Guard

Features a 3-stage (Low/Med/High) battery protection system to prevent vehicle battery depletion.



Smart Vehicle Integration

Fully compatible with Tesla's power systems, including specific considerations for latest vehicle software versions.



CAPACITY	15 L
RATED VOLTAGE	DC 12/24V
RATED POWER	45W
TEMPERATURE RANGE	-6 C TO 20 C
NOISE LEVEL	LESS THAN 45 DB
CLIMATE CATEGORY	T / ST / N
DIMENSIONS (LXWXH)	408X316X295





demmon

OPEN

88 ▲ ▼ ↻

AUTO REFRIGERATOR

DEMMON JNP SERIES

JNP-35



Tesla Rear Trunk Optimized

Tailor-made dimensions (818 mm width) designed to integrate seamlessly into the Tesla Model Y rear trunk compartment.



Smart Battery Guard

Features a 3-stage (Low/Med/High) battery protection system to prevent vehicle battery depletion.



Smart Vehicle Integration

Optimized to work with Tesla's power management systems, compatible with "Camp Mode" and "Sentry Mode" for continuous cooling.

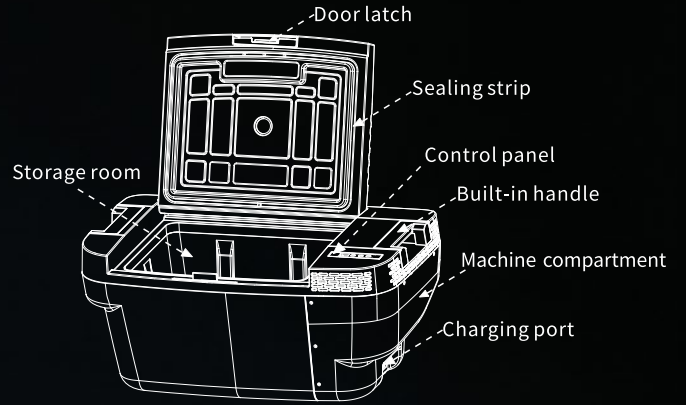

CAPACITY	35 L
RATED VOLTAGE	DC 12/24V OR AC 100-240V
RATED POWER	60W
TEMPERATURE RANGE	-20 C TO 20 C
NOISE LEVEL	LESS THAN 45 DB
CLIMATE CATEGORY	T / ST / N
DIMENSIONS (LXWXH)	788X458X359
NET WEIGHT	14 KG





AUTO REFRIGERATOR DEMMON DDM 75



Smart Battery Guard

Features a 3-stage (Low/Med/High) battery protection system to prevent vehicle battery depletion.



Universal Power

Fully compatible with DC 12/24V (Vehicle) and AC 100-240V (Home/Office) power sources.



User-Centric Design

Digital LED control panel with "MAX" (Fast Cooling) and "ECO" (Energy Saving) modes.

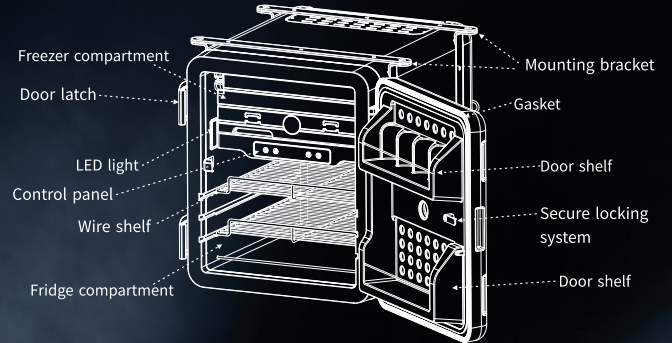

CAPACITY	75 L
RATED VOLTAGE	DC 12/24V
RATED POWER	80W
TEMPERATURE RANGE	FRIDGE: 0 C - 8 C FREEZER: -18C - 12 C
NOISE LEVEL	LESS THAN 45 DB
CLIMATE CATEGORY	T / ST / N
DIMENSIONS (LXWXH)	788X458X359
NET WEIGHT	27.3 KG

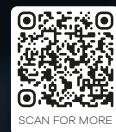

AUTO REFRIGERATOR DEMMON E30S



Smart Battery Guard

Features a 3-stage (Low/Med/High) battery protection system to prevent vehicle battery depletion.



Universal Power

Fully compatible with DC 12/24V (Vehicle) and AC 100-240V (Home/Office) power sources.

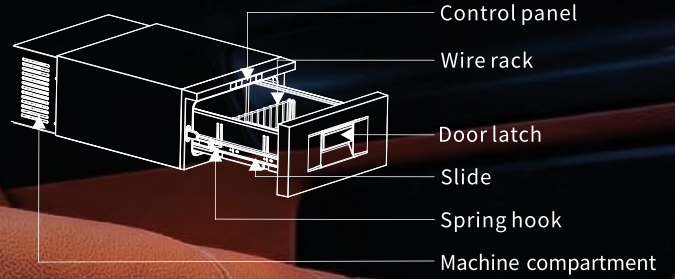

CAPACITY	20 L
RATED VOLTAGE	DC 12/24V OR AC 100-240V
RATED POWER	60W
TEMPERATURE RANGE	-20 C TO 20 C
NOISE LEVEL	LESS THAN 45 DB
CLIMATE CATEGORY	T / ST / N / SN
DIMENSIONS (LXWXH)	698X440X250
NET WEIGHT	17.6 KG



AUTO REFRIGERATOR DEMMON DMC 8



Smart Battery Guard

Features a 3-stage (Low/Med/High) battery protection system to prevent vehicle battery depletion.



Universal Power

Fully compatible with DC 12/24V (Vehicle) and AC 100-240V (Home/Office) power sources.



User-Centric Design

Digital LED control panel with "MAX" (Fast Cooling) and "ECO" (Energy Saving) modes.

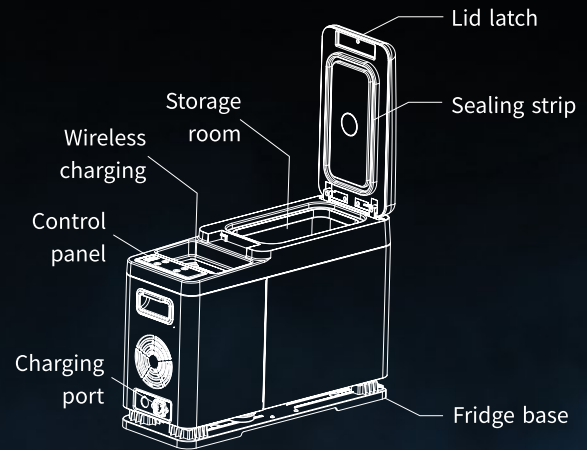

CAPACITY

8 L

RATED VOLTAGE

DC 12/24V AC 100-240V

RATED POWER

30W

TEMPERATURE RANGE

-20°C – 20°C

FAST COOLING

DOWN TO -15°C / 5°F

CLIMATE CATEGORY

T / ST / N / SN

DIMENSIONS (LXWXH)

788X458X359

NET WEIGHT

9 KG



AUTO REFRIGERATOR DEMMON VIP 15



Smart Battery Guard

Features a 3-stage (Low/Med/High) battery protection system to prevent vehicle battery depletion.



Universal Power

Fully compatible with DC 12/24V (Vehicle) and AC 100-240V (Home/Office) power sources.



Rechargeable Battery Option

Optional detachable battery system provides portable cooling performance without direct power connection.



Digital Control Panel

LED display enables precise temperature setting with MAX fast cooling and ECO energy-saving modes.



Cup Holder Design

Integrated cup holder and phone holder design improves convenience during travel.



CAPACITY	15 L
RATED VOLTAGE	DC 12/24V OR AC 100-240V
RATED POWER	45W
TEMPERATURE RANGE	-18 C TO 20 C
NOISE LEVEL	LESS THAN 45 DB
CLIMATE CATEGORY	T / ST / N
DIMENSIONS (LXWXH)	591X230X453
NET WEIGHT	8.9 KG



AUTO REFRIGERATOR DEMMON OTM 15



Smart Battery Guard

Features a 3-stage (Low/Med/High) battery protection system to prevent vehicle battery depletion.



Universal Power

Fully compatible with DC 12/24V (Vehicle) and AC 100-240V (Home/Office) power sources.



User-Centric Design

Digital LED control panel with "MAX" (Fast Cooling) and "ECO" (Energy Saving) modes.

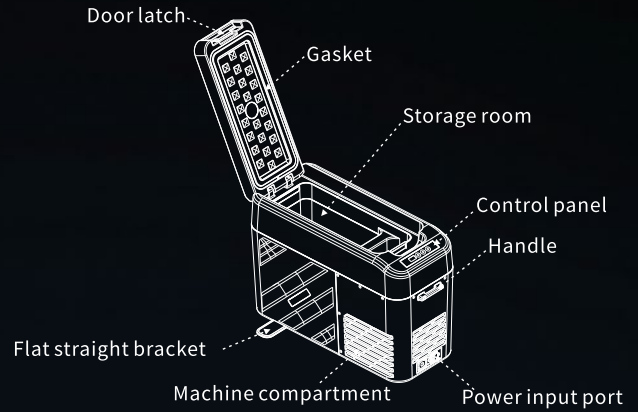

CAPACITY	15 L
RATED VOLTAGE	DC 12/24V AC 100-240V
RATED POWER	45W
TEMPERATURE RANGE	-20°C – 20°C
FAST COOLING	DOWN TO -20°C / -4°F
CLIMATE CATEGORY	T / ST / N
DIMENSIONS (LXWXH)	584X240X382
NET WEIGHT	8.2 KG



AUTO REFRIGERATOR DEMMON DME 18



Smart Battery Guard

Features a 3-stage (Low/Med/High) battery protection system to prevent vehicle battery depletion.



Universal Power

Fully compatible with DC 12/24V (Vehicle) and AC 100-240V (Home/Office) power sources.



Rechargeable Battery Option

Optional detachable battery system provides portable cooling performance without direct power connection.



Digital Control Panel

LED display enables precise temperature setting with MAX fast cooling and ECO energy-saving modes.



Bluetooth APP Control

Built-in Bluetooth connectivity allows smart control through the **mobile app** for convenient temperature adjustment.

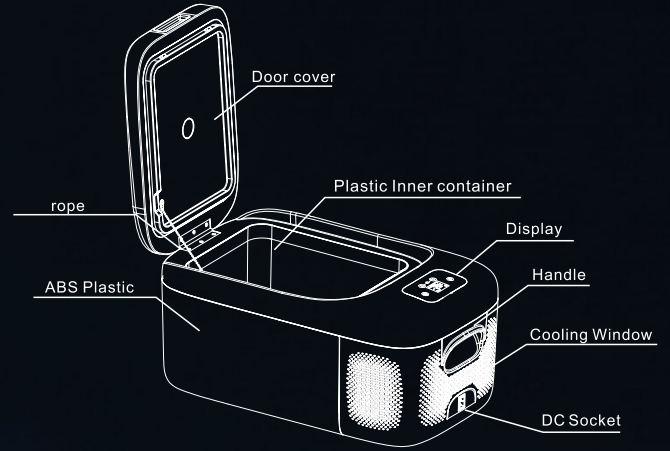

CAPACITY

15 L

RATED VOLTAGE

DC 12/24V OR AC 100-240V

RATED POWER

45W \pm 20%

TEMPERATURE RANGE

-18 C TO 20 C

NOISE LEVEL

LESS THAN 45 DB

CLIMATE CATEGORY

T / ST / N

DIMENSIONS (LXWXH)

568X330X362

NET WEIGHT

8.6 KG



AUTO REFRIGERATOR
FRIGUS A SERIES
 FR-A35B | FR-A45B | FR-A55B



Dual-Zone Technology

Two separate compartments with independent storage areas for versatile cooling and freezing.



Smart Battery Guard

Features a 3-stage (Low/Med/High) battery protection system to prevent vehicle battery depletion.



Universal Power

Fully compatible with DC 12/24V (Vehicle) and AC 100-240V (Home/Office) power sources.



User-Centric Design

Digital LED control panel with "MAX" (Fast Cooling) and "ECO" (Energy Saving) modes.



Bluetooth APP Control

Built-in Bluetooth connectivity allows smart control through the **mobile app** for convenient temperature adjustment.

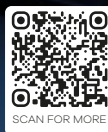
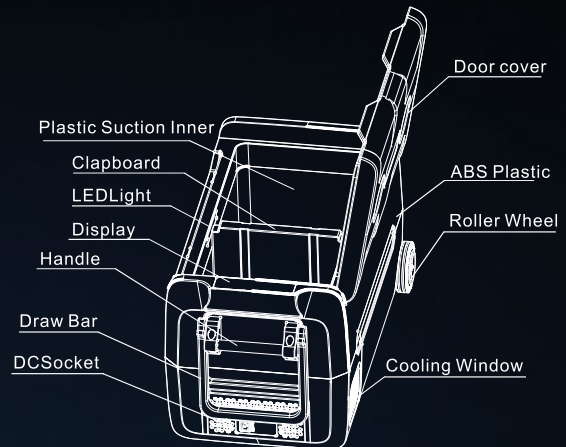

MODEL	FR-A35B	FR-A45B	FR-A55B
RATED POWER		45W ± 20%	
TEMPERATURE CONTROL RANGE		-20C - 20C	
NOISE LEVEL		Less than 45 dB	
NET WEIGHT	13.2 KG	14.1 KG	14.9 KG
TOTAL CAPACITY (LITERS)	35 L	45 L	55 L
DIMENSIONS (LxWxH)	726x390x373	726x390x443	726x390x513
INSULATION MATERIAL	POLYURETHANE FOAM		

AUTO REFRIGERATOR FRIGUS B SERIES

FR-B40A | FR-B50A | FR-B60A | FR-B40C | FR-B50C | FR-B60C



Dual-Zone Technology

Two separate compartments with independent storage areas for versatile cooling and freezing.



Smart Battery Guard

Features a 3-stage (Low/Med/High) battery protection system to prevent vehicle battery depletion.



Universal Power

Fully compatible with DC 12/24V (Vehicle) and AC 100-240V (Home/Office) power sources.



Rechargeable Battery Option

Optional detachable battery system provides portable cooling performance without direct power connection.



Digital Control Panel

LED display enables precise temperature setting with MAX fast cooling and ECO energy-saving modes.



Bluetooth APP Control

Built-in Bluetooth connectivity allows smart control through the **mobile app** for convenient temperature adjustment.

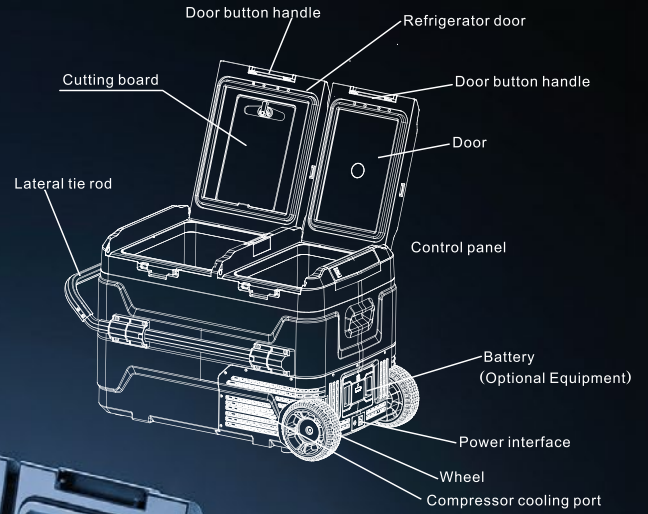

A Series is non-wheeled; C Series includes wheels and a pull rod for easy transport.

MODEL	FR-B40A FR-B40C	FR-B50A FR-B50C	FR-B60A FR-B60C
RATED POWER		60W ± 20%	
TEMPERATURE CONTROL RANGE		-20C - 20C	
NOISE LEVEL		Less than 45 dB	
NET WEIGHT	18.3 KG	18.8 KG	19.3 KG
TOTAL CAPACITY (LITERS)	40 L	50 L	60 L
DIMENSIONS (LxWxH)	674x409x466	674x409x516	674x409x583
INSULATION MATERIAL	POLYURETHANE FOAM		

AUTO REFRIGERATOR **FRIGUS FR-C18A**



Smart Battery Guard

Features a 3-stage (Low/Med/High) battery protection system to prevent vehicle battery depletion.



Universal Power

Fully compatible with DC 12/24V (Vehicle) and AC 100-240V (Home/Office) power sources.



Rechargeable Battery Option

Optional detachable battery system provides portable cooling performance without direct power connection.



Digital Control Panel

LED display enables precise temperature setting with MAX fast cooling and ECO energy-saving modes.



Bluetooth APP Control

Built-in Bluetooth connectivity allows smart control through the **mobile app** for convenient temperature adjustment.

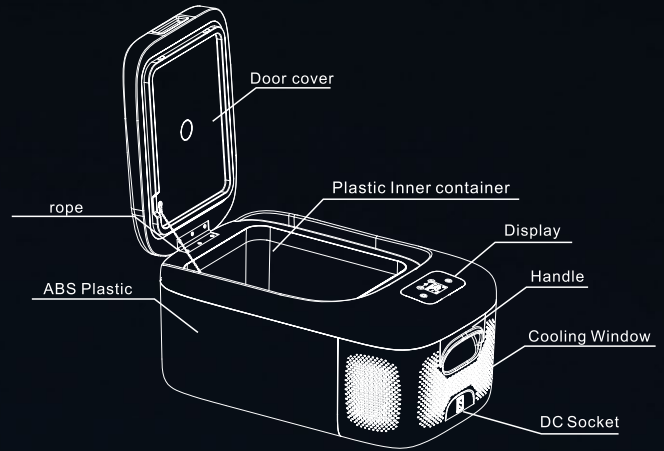

CAPACITY	15 L
RATED VOLTAGE	DC 12/24V OR AC 100-240V
RATED POWER	45W ± 20%
TEMPERATURE RANGE	-18 C TO 20 C
NOISE LEVEL	LESS THAN 45 DB
CLIMATE CATEGORY	T / ST / N
DIMENSIONS (LXWXH)	568X330X362
NET WEIGHT	8.6 KG





DIESEL HEATER

DIESEL HEATER
DEMMON THERMON
 THERMON 2 | 4



High Heating Performance

Available in 2.8 kW and 5 kW heating capacities to meet different vehicle and cabin heating needs.



Wide Altitude Operation

Stable performance in high-altitude environments: up to 3000 m for civilian use and 5500 m for military use.



Extreme Cold Performance

Built to operate reliably in harsh winter conditions down to -41°C.



Automatic Protection Functions

Includes fault diagnosis, automatic shutdown, cooling mode and self-check functions for safer operation.



MODEL	THERMON 2	THERMON 4
HEATING CAPACITY	2.8 KW	5 kW
WEIGHT	2.8 KG	4.5 kg
DIMENSIONS (L×W×H)	310×115×122	376×140×150
HOT AIR FLOW	90 M ³ /H	150 M ³ /H
NOMINAL POWER CONSUMPTION	36W	50W
FUEL CONSUMPTION	0.36 L/H	0.60 L/H
OPERATING TEMPERATURE	-41°C – +50°C	
STORAGE TEMPERATURE	-55°C – +70°C	

DIESEL HEATER
DEMMON ECOTHERM
 ECOTHERM 2 | 4



High Heating Performance

Available in 2.5 kW and 5 kW heating capacities to meet different vehicle and cabin heating needs.



TFT Control Panel

Smart control panel allows easy operation, temperature adjustment and system monitoring.



Remote Control Support

Remote control provides convenient ON/OFF operation and adjustment from a distance.



Safety-Focused Design

Designed with proper combustion air intake and external exhaust routing for safer vehicle installation.



MODEL	ECOTHERM 2	ECOTHERM 4
HEATING POWER	750W – 1950W	1450W – 5000W
WEIGHT	2.8 KG	4.5 kg
DIMENSIONS (L×W×H)	310×115×122	376×140×150
HOT AIR FLOW	90 M ³ /H	150 M ³ /H
NOMINAL POWER CONSUMPTION	36W	50W
FUEL CONSUMPTION	0.10 – 0.25 L/H	0.15 – 0.45 L/H
OPERATING TEMPERATURE	-40°C – +55°C	

DIESEL HEATER DEMMON ECOTHERM MOVE



Rapid Heating Technology

Ceramic glow plug technology enables fast fuel vaporization and quick hot air output within seconds.



Wide Altitude Operation

Stable performance in high-altitude environments: up to 3000 m for civilian use and 5000 m for military use.



Smart LCD Control Panel

Digital LCD panel displays real-time temperature, voltage and error codes for easy monitoring.



Advanced Safety Package

Equipped with overheating protection, low-voltage protection and combustion sensor for safer operation.



HEATING POWER

2KW / 5KW / 8KW

VOLTAGE OPTIONS

DC 12V / 24V, AC 220V

FUEL CONSUMPTION

0.11 – 0.48 L/H

NOMINAL POWER CONSUMPTION

15 – 40W

STARTING CURRENT

8 – 12A

OPERATING TEMPERATURE

-40°C – +50°C

DEVICE WEIGHT

APPROX. 4.5 – 9.5 KG

AIR FLOW

120 – 190 M³/H

DIESEL HEATER
RAINO RAINOTHERM
RAINOTHERM 2 | 4



High Heating Performance

Available in 2.5 kW and 5 kW heating capacities to meet different vehicle and cabin heating needs.



LCD Control Panel

Universal LCD control panel allows easy operation, temperature adjustment and system monitoring.



Remote Control Support

Remote control provides convenient ON/OFF operation and adjustment from a distance.



Safety-Focused Design

Designed with proper combustion air intake and external exhaust routing for safer vehicle installation.



MODEL	RAINOTHERM 2	RAINOTHERM 4
HEATING POWER	750W – 2000W	1450W – 5000W
WEIGHT	2.8 KG	4.5 kg
DIMENSIONS (L×W×H)	310×115×122	376×140×150
HOT AIR FLOW	90 M ³ /H	150 M ³ /H
NOMINAL POWER CONSUMPTION	36W	50W
FUEL CONSUMPTION	0.10 – 0.25 L/H	0.16 – 0.48 L/H
OPERATING TEMPERATURE	-40°C – +55°C	

DIESEL HEATER DEMMON ECOTHERM MOVE



Rapid Heating Technology

Ceramic glow plug technology enables fast fuel vaporization and quick hot air output within seconds.



Wide Altitude Operation

Stable performance in high-altitude environments: up to 3000 m for civilian use and 5000 m for military use.



Smart LCD Control Panel

Digital LCD panel displays real-time temperature, voltage and error codes for easy monitoring.



Advanced Safety Package

Equipped with overheating protection, low-voltage protection and combustion sensor for safer operation.



HEATING POWER

2KW / 5KW / 8KW

VOLTAGE OPTIONS

DC 12V / 24V, AC 220V

FUEL CONSUMPTION

0.11 – 0.48 L/H

NOMINAL POWER CONSUMPTION

15 – 40W

STARTING CURRENT

8 – 12A

OPERATING TEMPERATURE

-40°C – +50°C

DEVICE WEIGHT

APPROX. 4.5 – 9.5 KG

AIR FLOW

120 – 190 M³/H



PORTABLE KETTLES

PORTABLE KETTLE
DEMMON 1.2L PORTABLE KETTLE



Adjustable Warm Setting

Warm mode supports adjustable temperature levels between 40°C and 80°C.



Boil & Warm Modes

Supports both boiling and warming functions for different hot water needs.



304 Stainless Steel Inner Liner

Inner liner made of 304 stainless steel for cleaner, safer and more durable use.



1.2L Capacity

Practical 1.2L rated capacity for daily use, travel, camping and long road trips.



RATED CAPACITY	1.2L
RATED VOLTAGE OPTIONS	12V / 24V / 220V
RATED POWER OPTIONS	100W / 200W / 300W
WARM TEMPERATURE RANGE	40°C – 80°C
INNER LINER	304 STAINLESS STEEL
FUNCTIONS	BOIL / WARM
CONTROL TYPE	DIGITAL DISPLAY CONTROL
APPLICATION	VEHICLE / TRAVEL / CAMPING

PORTABLE KETTLE
DEMMON 0.8L PORTABLE KETTLE



Auto-Off Function

Automatically turns off after boiling for safer and more convenient use.



Soft Touch Control

Easy-to-use soft touch switch provides simple boiling operation.



Dry Boil Protection

Built-in dry boil protection helps prevent damage when the kettle is operated without water.



0.8L Capacity

Compact 0.8L body design makes it ideal for vehicle use, travel, camping and daily hot water needs.



RATED CAPACITY

0.8L

RATED VOLTAGE OPTIONS

12V / 24V

RATED POWER OPTIONS

12V: 170W / 24V: 300W

WARM TEMPERATURE RANGE

40°C – 80°C



📍 Akşemseddin Mah, 265/1 Sk
No:23, 34510 Esenyurt/İstanbul

☎ +90(212) 864 39 03

✉ info@demmon.com.tr

📷 demmontr